

Manual Stencil and Screen Printer

SPM-001 Data Sheet

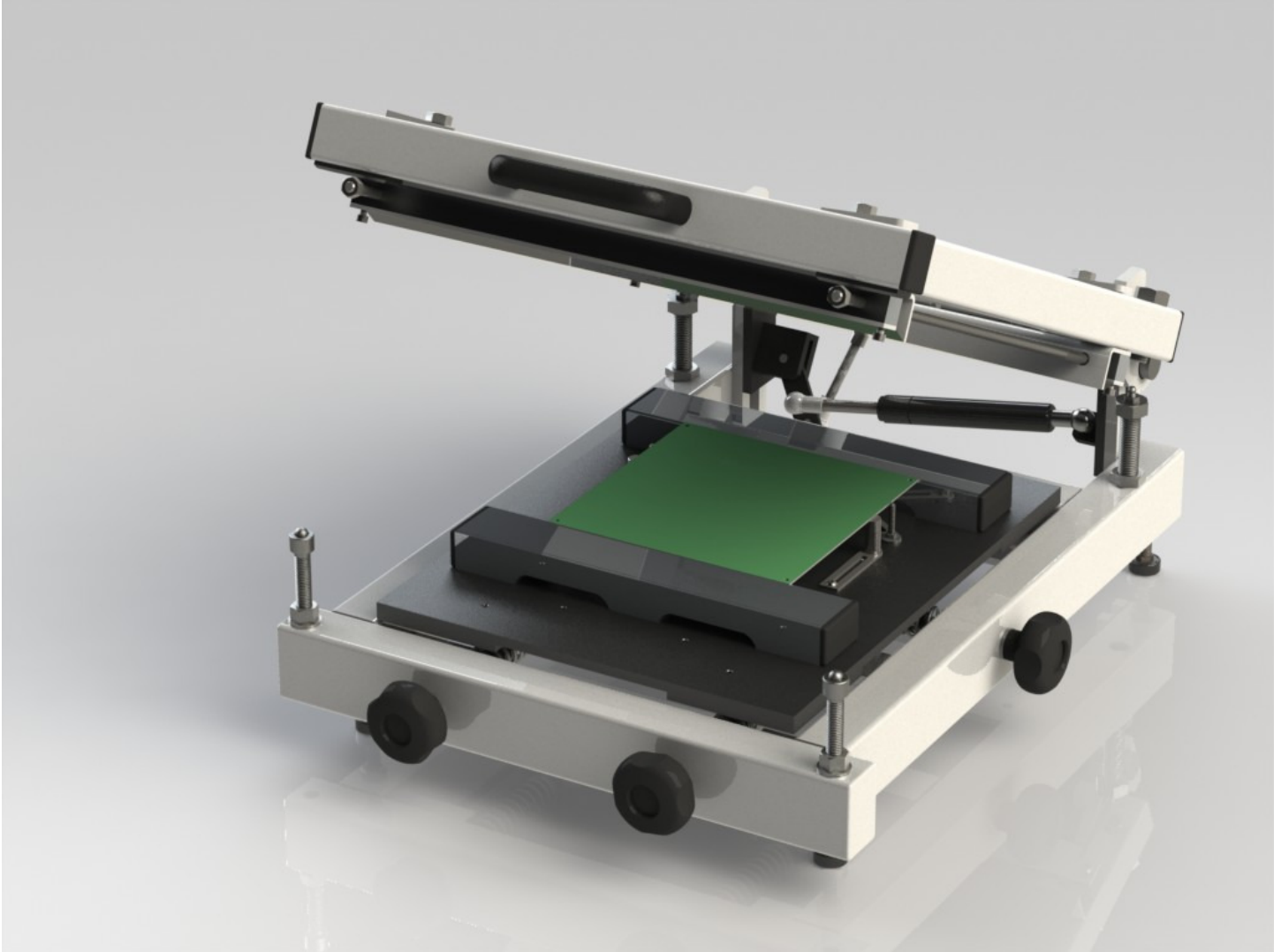

- Ideal for low volume printing
- Suitable for heavy duty
- Rigid steel construction, high dimensional stability
- Robust design guarantee a long life time
- Printing of solder paste, glue and ink in electronic production
- Pre-loaded mechanism for precise x/y/theta adjustment
- Gas spring support for frame opening
- Holders for PCB
- Several stencil and screen fixing options

Technical Description

- The machine has a table with ± 5 mm x, y and $\pm 3^\circ$ theta adjustment.
- The design of the upper frame and different screen frame holders enables setting with free space of maximum 130 mm below the screen.
- Maximum stencil frame height is 30 mm.
- The upper frame is very precisely aligned to the lower frame by means of ball fitting in bush.
- The main shaft for opening the upper frame does not affect aligning of lower and upper frame. Precision of machine is not affected by any wearing.
- Upper frame is finely balanced with gas-spring strut, the balancing force of which can be easily adjusted.
- When changing the position of the upper frame, the balancing forces remain the same.

3 different screen frame holders

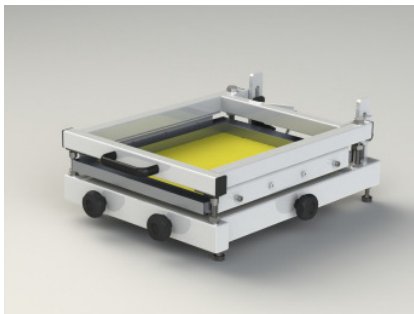

Side frame holder

Supports for stencils and screens in the following sizes x: 400 – 417 mm, y: max. 500mm, z: 20 mm – 30 mm.

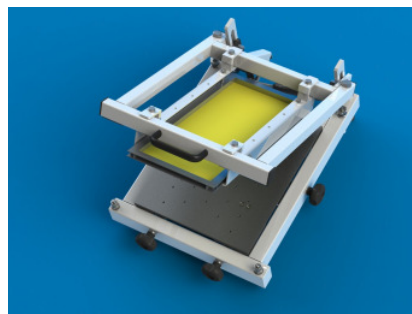

Internal „C” holder

For frames x: max. 330 mm, y: max. 500 mm and z: max. 30 mm. Distance between the table and the bottom of the screen is at least 3 mm.

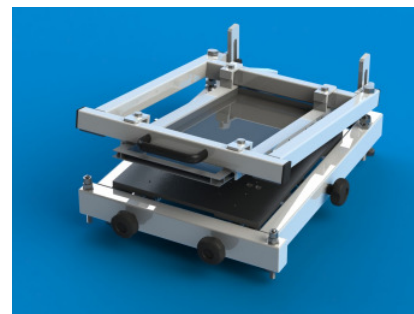

Internal „L” holder

Enables simple z-direction fine adjustment when used for stencils. Maximum stencil sizes are the same as the C holder.

For taller objects to be printed

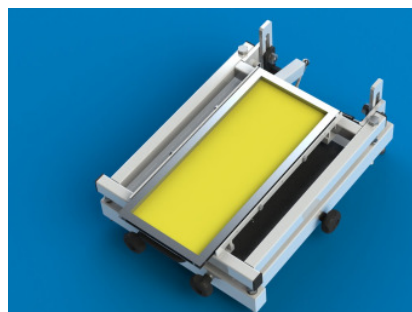
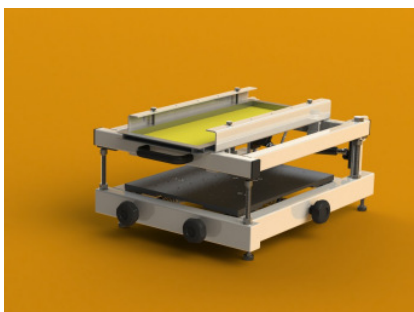

Upside down „C” and „L” holders

When mounting internal screen frame holders upside down, the maximum free space between the bottom of the screen and the table is 136 mm.

Stencil tensioning frame and magnetic table



Stencils up to 450 mm x 420 mm can be used with the tensioning screw stencil frame. Sencil can be accurately clamped into the frame and no need for registration holes. Two clamping plates with 22 screws properly secure the sencil to the tensioning frame. The tensioning frame is fixed to the top frame of the printer in the same way to the screen holders.

PCBs mounted with SMD components on both sides are secured to the magnetic table with the supporting pins, bars, hole and edge fixation pins.

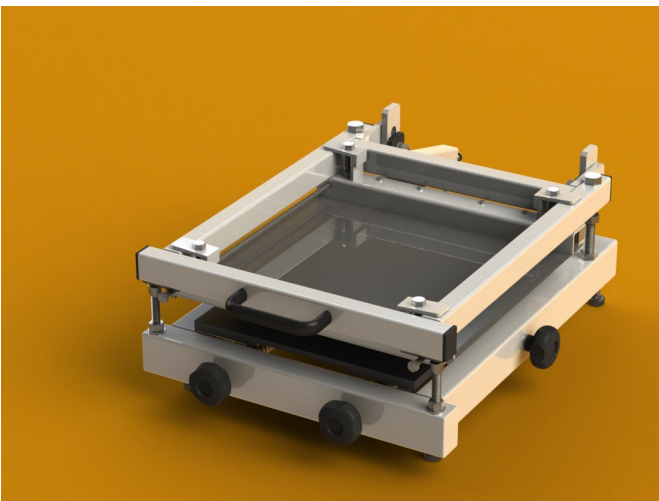

Stencil tensioning frame

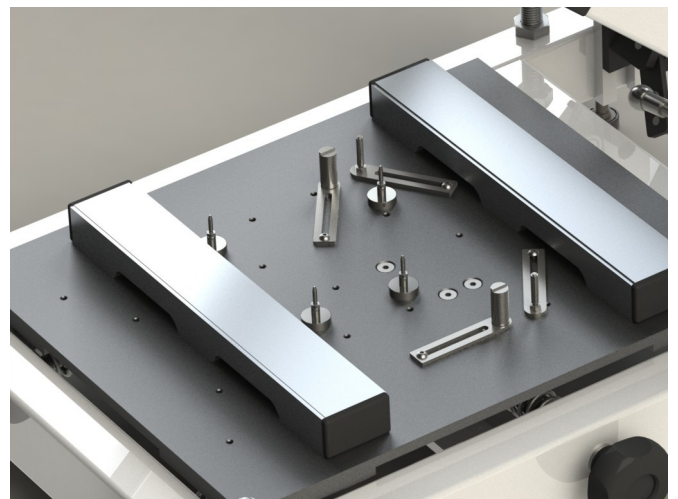

PCB support columns

The support can be used for double-sided PCBs with a thickness of 0.5 mm to 1.6 mm.

Easy opening

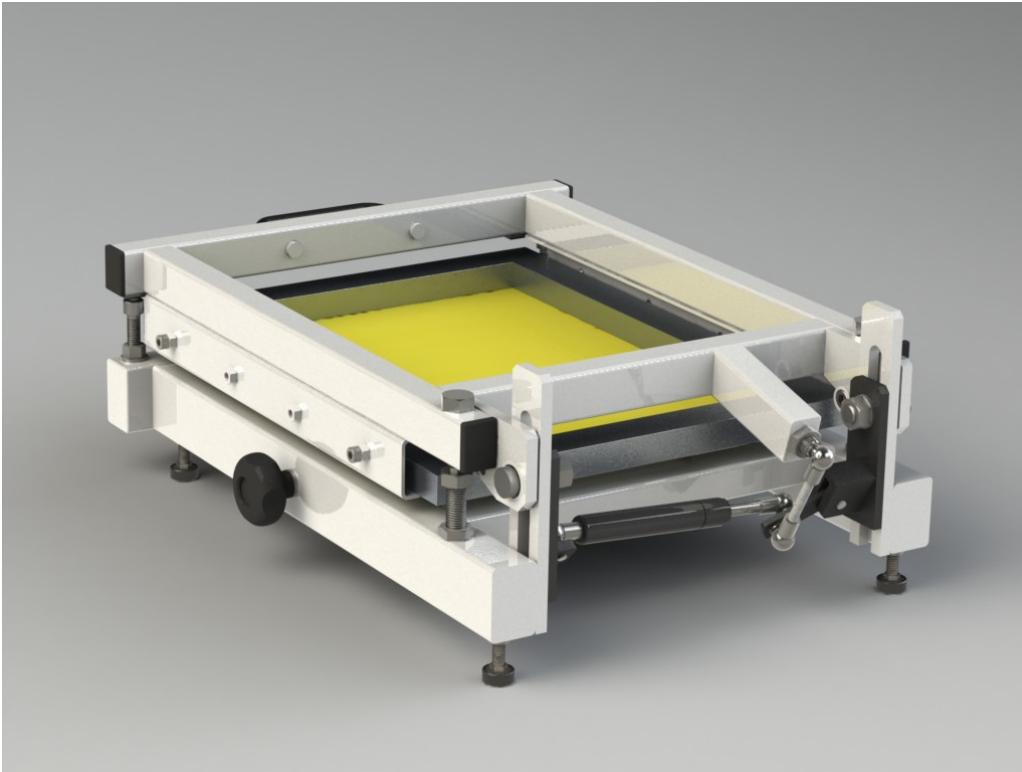

Gas-spring strut

When opening the upper frame, the balancing force can be easily adjusted to frame holders and screens of different weights.

Bigger upper frame

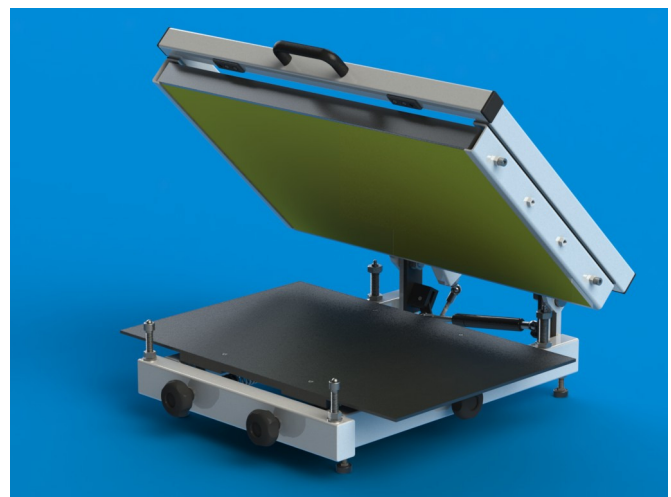
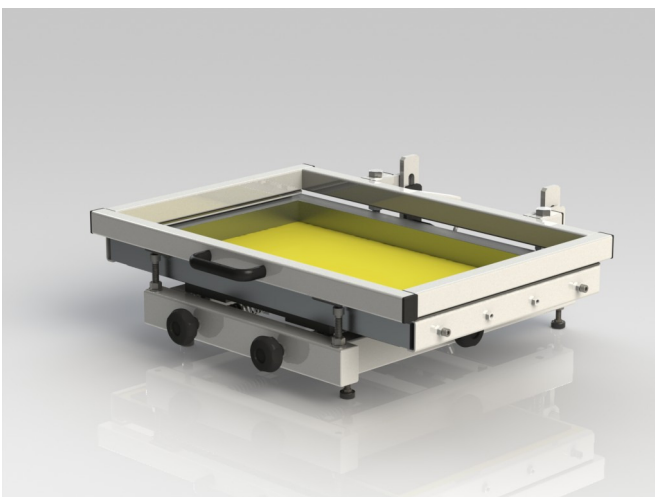

Optional installable wide upper frame and table

A larger area may be needed during screen printing, so a 724 mm wide upper frame with counterweight and table can be installed for this special purpose. Internal „C” and „L” holders can be used with the wide upper frame as well as side holders. Maximum screen frame dimensions 712 mm x 470 mm x 30 mm.

Specifications

Machine type	Manual stencil/screen printer	
Alignment sytem	Manual	
PCB handling	PCB size max. (LxWxH)	
	Tensioning frame	360 x 320 x 30 mm
	Side frame holder	400 x 320 x 30 mm
	Double-sided	320 x 300 x 30 mm
	Double-sided PCB min. height	0.5 mm
Screen handling	Screen frame size max. (LxWxH)	
	Side frame holder	500 x 417 x 30 mm
	Internal „C” holder	500 x 330 x 30 mm
	Internal „L” holder	500 x 330 x 30 mm
	Side frame holder min. width	400 mm
	Screen size max. for big upper frame (LxWxH)	470 x 712 x 30 mm
	Max. printing height	
	Side frame holder Upside down „C” and „L” holders	46 mm 136 mm
Print table size	(LxW)	
	Base	420 x 340 mm
	Installable for big upper frame (optional)	420 x 640 mm
Alignment and accuracy	XY alignment range	± 5 mm
	Theta	± 3 °
	Accuracy	± 20 µm
Included accessories	Internal „L” holder	
	Side frame holder	
	Mounting screws	
Optional accessories	Internal „C” holder	
	Tensioning screw stencil frame	
	PCB support	4pcs magnetic support pins, 2pcs hole support bars, 2pcs edge fixation bars, 2pcs 50 x 30 x 300 mm magnetic PCB edge supports
	724 mm wide upper frame	
	Installable table for wide upper frame	Dimensions: 420 x 640 x 5 mm, material: steel
Machine material		Steel
	Surface finish	Epoxy primer + solvents and scratch-resistant 2K polyurethane acrylic paint
Machine dimensions	Incl. legs (LxWxH)	680 x 480 x 320 mm
	Machine weight (excl. accessories)	30 kg

Copyright ©GEM Microwave. All rights reserved. GEM Microwave products are covered by patents, issued and pending. Information in this publication supersedes that in all previously published material. Specification and price change privileges reserved. GEM Microwave and GEMTEK are registered trademarks of GEM Microwave. All other trade names referenced are the service marks, trademarks, or registered trademarks of their respective companies.

16 Dec 2017 201712

